



Product Specifications



Version:A1

Model: DGA501II

Issue date: 2024/7/22





Overview

This specification aims to provide a detailed description of the technical specifications, performance requirements, and functional characteristics of the relevant products to meet the application needs in different scenarios. Provide a unified reference standard for suppliers, engineers, and customers, and ensure that products can meet expected requirements and operate safely and reliably.

The compilation of this specification book refers to industry standards, national regulations, and relevant technical requirements, and comprehensively regulates the core technology, component selection, system performance, safety performance, control and monitoring of the product. At the same time, this specification also provides requirements for delivery acceptance, maintenance, and after-sales service to ensure the quality and reliability of the product.

During the preparation process of this specification, we listened to the opinions and suggestions of suppliers, engineers, and customers, striving to make the content of the specification reasonable, feasible, and as consistent as possible with existing industry standards and specifications. However, due to the continuous development of technology and market, this specification may need to be updated and modified according to actual application situations.

DGA501II SPECIFICATION

Update records

Accumulate update records for each document update, with the latest version containing updated content from all previous document versions. Document version: A01 (July 22, 2024)

The document is officially released.



Catalogue

Preface	1
Overview	1
Updating Records	1
Catalogue	2
1. Product Overview	3
1. 2 Product Description:	3
2. Product Specification Parameters	3
3. Testing Conditions and Methods.....	4
3. 1 Testing Product Standards	4
3. 2 Testing environment standards	4
4. Interface Performance.....	4
5. Electrical parameters.....	5
6. Product Drawings.....	6
6. 1. Product Dimensional Drawing.....	8
6. 2 Interface Definition.....	8
6. 3 indicator lights display status	9
6. 4 DIP switches.....	9
6. 5 Communication Interfaces.....	10
7. Basic parameters of battery cell	11
8. Basic parameters of battery module.....	12
9. Basic parameters of BMS.....	13
10. Instructions for Use.....	14
10. 1 Charging Requirements.....	14
10. 2 Discharge Requirements.....	14
10. 3 Storage Requirements.....	14
10. 4 Shipping Charged.....	14
11. Warn.....	15
12. Attention.....	16
13. Warranty.....	16
14. Others.....	16



1. Product Overview

1.1 Product Name:

Xingcheng DGA501II Household Energy Storage Power Supply (here in after referred to as "the battery" in the document)

1.2 Product Description:

The battery uses brand new and A grade EVE lithium iron phosphate prismatic cell as the main energy storage component, with excellent cell performance and consistency, as well as a long cycle life, which can better meet user needs. The power supply casing is made of thickened steel plate through electrostatic spraying, ensuring the battery structure is sturdy and reliable. Equipped with a high-quality battery intelligent management system, ensuring the stability and reliability of the power supply. In addition, the power output port adopts a quick plug-in connector, which is easy for users to operate and has strong overcurrent capability. At the same time, the Canbus/RS485 communication interface is configured, which can be compatible with various mainstream brands of inverters in the market, providing greater compatibility and flexibility.

2. Product Specification Parameters

Nominal voltage	51.2V
Nominal capacity	100Ah
Energy	5.12KWh
Working voltage	40.8~58.4V
Charging voltage	58.4V MAX
Standard charging current	20A (at 0.2C)
Maximum charging current	100A (Should base on the working current of the protection board)
Discharge cut-off voltage	40V
Standard discharge current	20A
Maximum discharge current	100A (Should base on the working current of the protection board)
Cell model	LF100LA 100Ah
material of the shell	Cold-rolled steel plate
Protection level	IP51
Cooling method	Natural cooling
External dimensions	440*480*133±1mm(excluding installation bracket)
Battery weight	≈48kg excluding installation configuration parts
Working temperature	Charge: 0 C~45°C At10%-90%RH Discharge: -20°C-60°C At10%-90%RH

Note: For the above testing items, the testing conditions should comply with all the contents of the third main item " Testing Conditions". If any of the working conditions of the battery exceed the range of the third main item, there will be a certain deviation in the performance of the battery.



3. Testing Conditions and Methods

3.1 Testing Standards

3.1.1 The test should use new battery packs delivered within 15 days and have not undergone more than 5 charging and discharging cycles.

3.1.2 The test should be conducted in an environment with a temperature of 25 ± 2 , a relative humidity of 15 %-90% RH, and an atmospheric pressure of 86kPa ~ 106kPa. The room temperature mentioned in this specification refers to 25 ± 2 .

3.2 Testing Method Standards

NO	Test Item	Testing Mode
3.2.1	Standard Charging	Constant current charging: Initially, a constant current of 0.5C is used for charging until the set voltage is reached. Constant voltage charging: After reaching the charging voltage, switch to constant voltage charging mode. Reduce current: In constant voltage mode, the current gradually decreases to 0.01C.
3.2.2	Standard Discharge	Constant current discharge: Discharge at a constant current of 0.5C until the discharge cutoff voltage is reached.
3.2.3	Charge-discharge Cycle	Charging stage: Charge to full capacity according to the requirements of item 3.3.1 and let it stand for 0.5-1 hour. Discharge stage: Discharge according to the requirements of item 3.3.2 until the end, and let it stand for another 0.5-1 hour. Repeated cycle: After completing one charge and discharge cycle, charge and discharge again, maintaining a standing time of 0.5-1 hour between each cycle

Note: For the above testing methods, they must meet the standards required in 3.1 and 3.2. The charging and discharging current and voltage parameters involved in the testing method shall be subject to the second product specification parameter.

4、Interface Performance

NO	Test Item	Performance Description	
4.1	Parallel Use	Supports up to 15 battery packs for external parallel operation, mainly used for battery expansion and power increase.	
4.2	Communication	External communication interface Can/RS485: mainly used for communication with inverters and reading battery information using PCs; Internal communication interface RS485: Used for battery parallel communication and reading battery information using a PC.	
4.3	Adapted Inverter	Canbus Interface	SMA, Victron, PYLONTECH, DEYE, Growatt, Sacolar, MEGARE VO, SOFAR, Goodwe, MUST, TBB
		RS485 Interface	PYLONTECH, DEYE, Growatt, Sacolar, Voltronic, SRNE, SAJ

Parallel use:

1. When the battery is used in parallel, a junction box needs to be installed, and the positive and negative poles of each battery group need to be connected to the junction box.
2. External parallel connection is the communication and coordination between BMS to meet the unified monitoring of the battery by the host computer. The battery itself does not have load balancing, synchronous control and other functions. To achieve the above functions, additional related equipment needs to be purchased.

5、Electrical parameters

Function	Effective	Item	Typical Value	Range Value	Remark
Overall voltage alarm	Open	Overcharge alarm voltage	57.6V	± 40mV	Configurable
		Overdischarge alarm voltage	44.8V	± 40mV	Configurable
Overall overcharge protection	Open	Overcharge protection voltage	58.4V	± 40mV	Configurable
		Overcharge protection delay	1s	200-1800ms	Configurable
		Overcharge recovery voltage	53.6V	± 300mV	Configurable
Overall over discharge protection	Open	Overdischarge protection voltage	40V	± 300mV	Configurable
		Overdischarge protection delay	1s	500-3000ms	Configurable
		Overdischarge recovery voltage	47.2V	± 600mV	Configurable
Charging overcurrent	Open	Charge alarm current	105A	± 2A	Configurable
Charging overcurrent protection	Open	Charge protection current	110A	± 2A	Configurable
		Charge overcurrent delay	1.2S	± 0.6s	Configurable
Discharge overcurrent	Open	Discharge alarm current	105A	± 2A	Configurable
Discharge overcurrent protection	Open	Discharge protection current	110A	± 10A	Configurable
		Discharge overcurrent delay	10s	± 2s	Configurable
Secondary overcurrent protection	Open	Secondary protection current	≥250A	± 3A	Configurable
		Secondary overcurrent delay	500ms	100-1500ms	Configurable
Charging current limit		Charge current limit value	10A		30 min attempt
Discharge overcurrent		Automatic recovery delay		After 32s autorecover	3 times locked

6、Drawing

Pic 1



产品尺寸

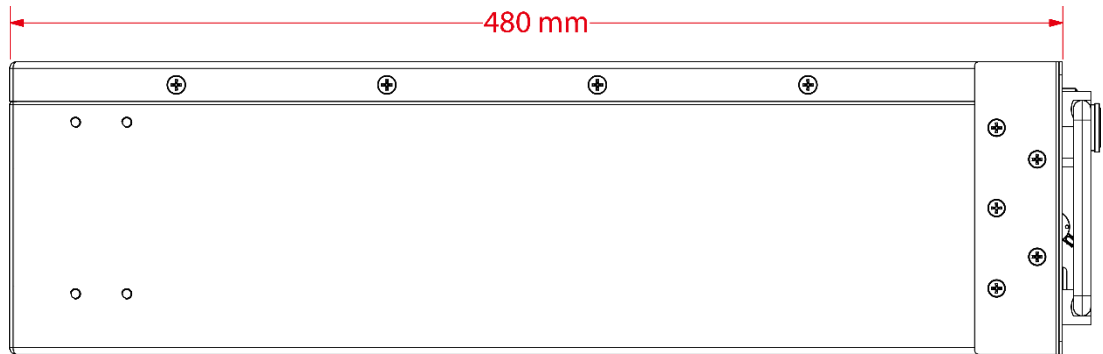
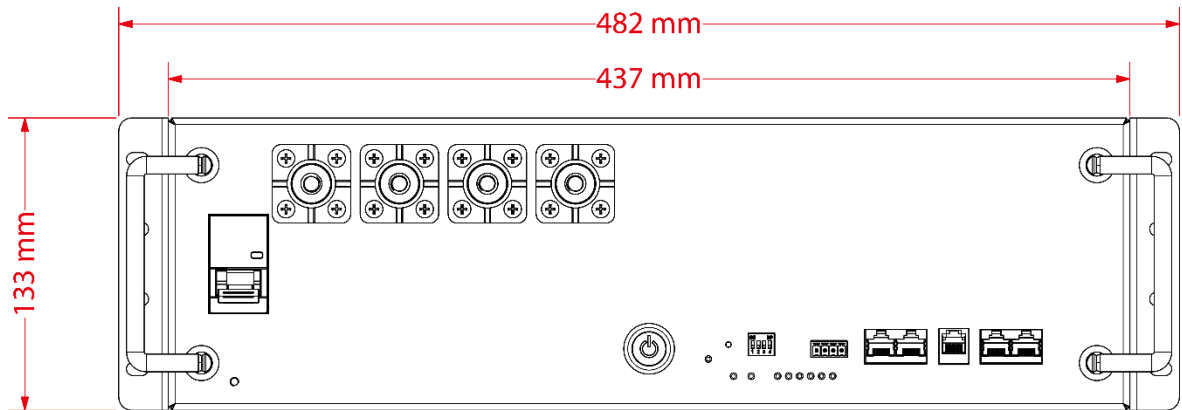

木箱尺寸

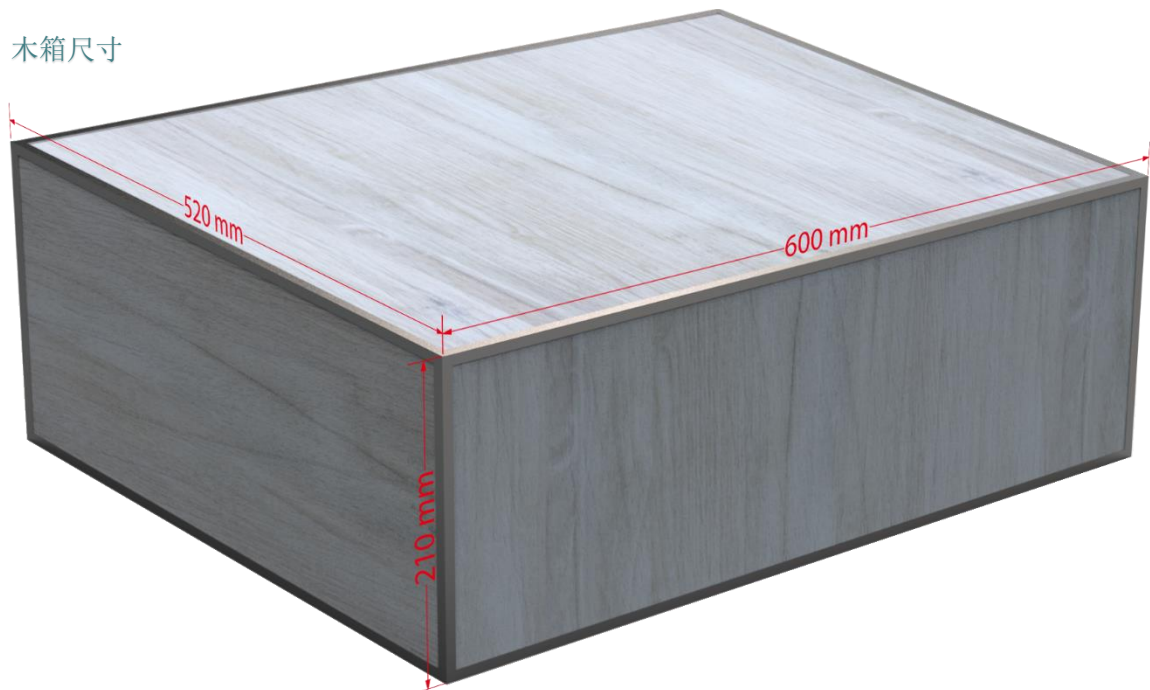

6. 2 接口定义

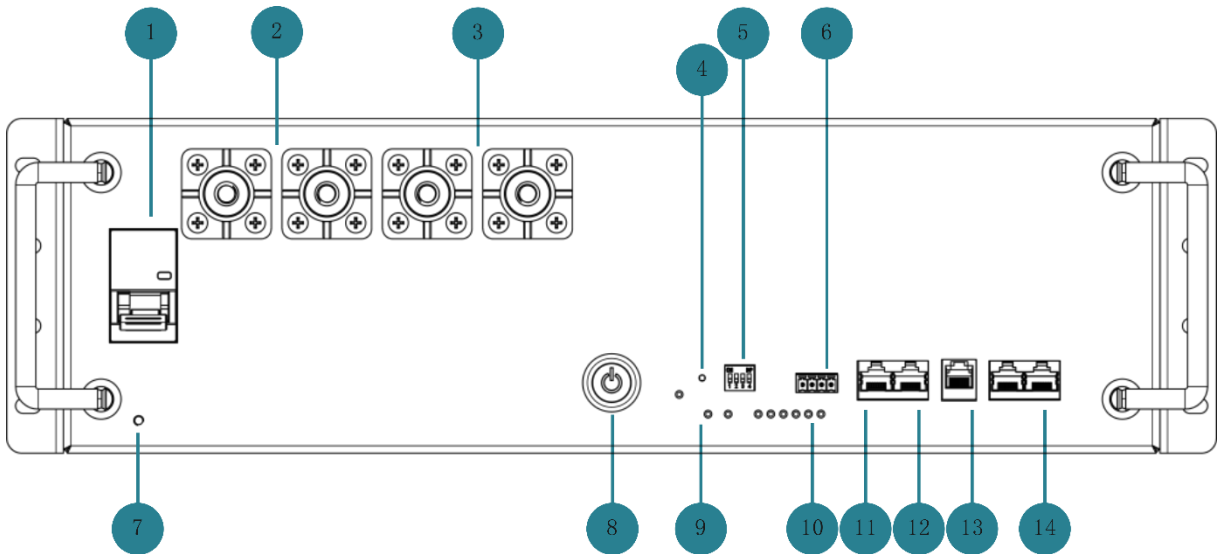

14	Communication Port	RS485-2-RJ45Communication Port
13	Communication Port	RS232-RJ11Communication Port
12	Communication Port	CAN-RJ45Communication Port
11	Communication Port	RS485-1-RJ45Communication Port
10	LEDindicator light	SOC indicator light
9	LEDindicator light	Operation status indicator light
8	Weak current switch	BMSswitch
7	GDN	Grounding
6	Dry contact interface	KF2EDG 3.81MMPlug-in terminal blocks
5	Dip switch	When performing multi machine parallel communication operations,it is necessary to first configure the dialing address.
4	Reset switch	Reset button switch (hidden), long press for 3S to take effect.
3	P-	Negative connector, input and output negative interface.
2	P+	Positive connector, input and output positive interface.
1	breaker	Positive input and output power switch
Remark		

6.3 Indicator Light Display

6.3.1 Self check mode

When the "power on" button is pressed, the battery BMS starts working, and the indicator light status is as follows:





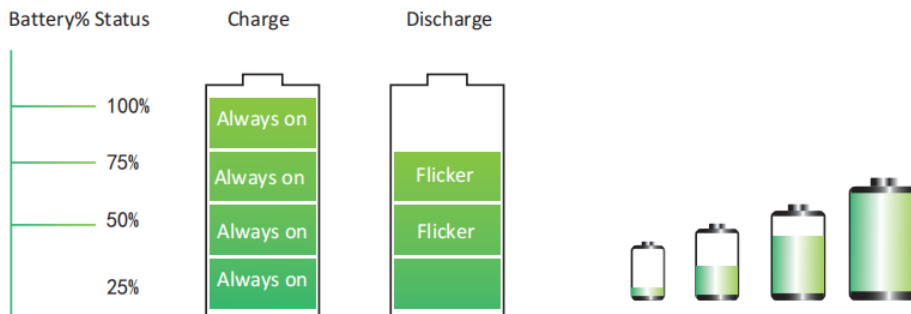





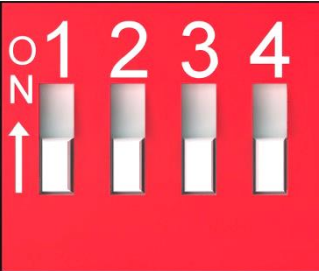





- The bottom LED starts to light up the red light, and then lights up the red light in sequence from bottom to top until all LEDs light up the red light at the same time, and then goes out synchronously;
- The bottom LED starts to light up the yellow light, and then lights up the yellow light sequentially from bottom to top until all LEDs light up the yellow light at the same time, and then goes out synchronously;
- The bottom LED starts to light up the green light, and then lights up the green light sequentially from bottom to top until all LEDs light up the green light at the same time. The self check ends and enters the working state.

6.3.2 Battery indicator



6.4 DIP Switch

When parallel use is required, the unique address of the power supply can be set through a dip switch to distinguish between different power sources. The detailed definition of power address is as follows:

	No.	Switch address	No.	Switch address
<p>Using BCD code format, the definition of address 0 is as follows:</p>  <p>The host address code must be 0, and addresses are assigned from 1 to 15 for the slave.</p>	0	 0000	8	 0001
	1	 1000	9	 1001
	2	 0100	10	 0101
	3	 1100	11	 1101
	4	 0010	12	 0011
	5	 1010	13	 1011
	6	 0110	14	 0111
	7	 1110	15	 1111

6.5 Communication interface

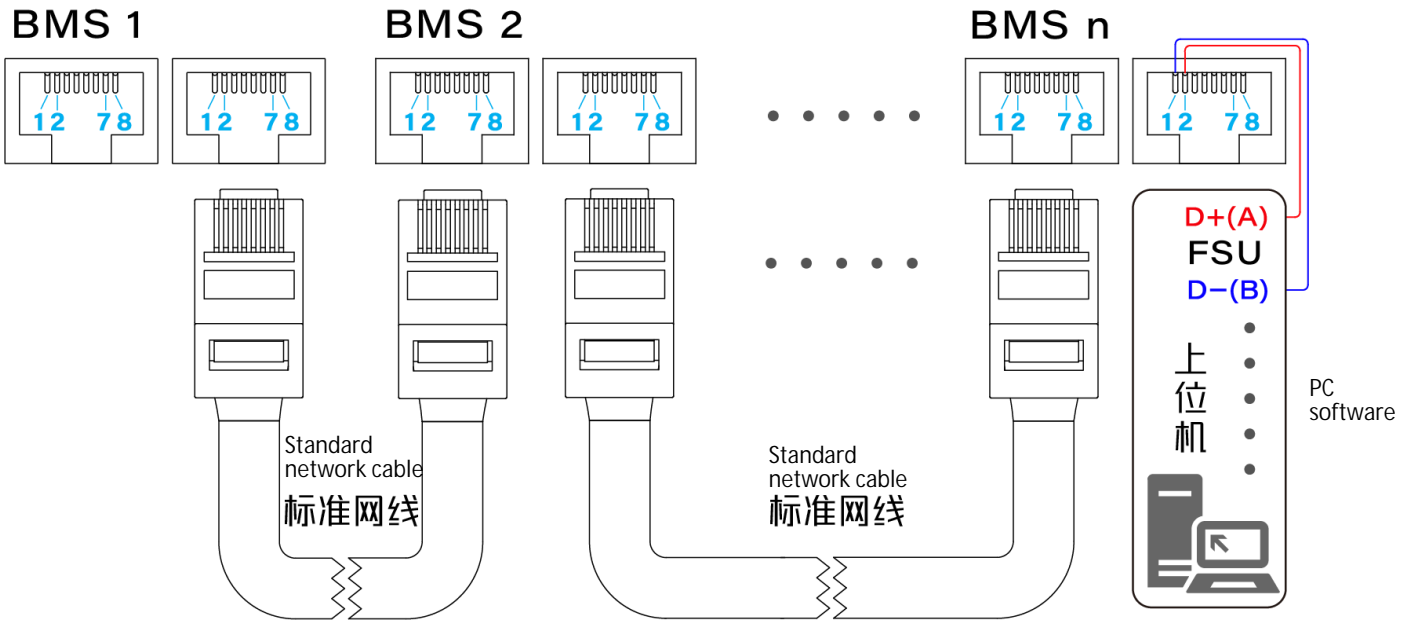

RS232--Using 6P6C vertical RJ11 socket	
RJ11 Pin	Definition Description
2	NC
3	TX (single board)
4	RX (single board)

RS485--Adopting 8P8C vertical RJ45 socket		CAN - adopts 8P8C vertical RJ45 socket	
RJ45 pin	Definition Description	RJ45 pin	Definition Description
1.8	RS485-B1	9、10、11、14、16	NC
2.7	RS485-A1	12	CANL
3.6	GND	13	CANH
4.5	NC	15	GND

CAN and RS485 interface

RS485--Adopting 8P8C vertical RJ45 socket		RS485- using 8P8C vertical RJ45 socket	
RJ45 pin	Definition Description	RJ45 pin	Definition Description
1.8	RS485-B	9、16	RS485-B
2.7	RS485-A	10、15	RS485-A
3.6	GND	11、14	GND
4.5	NC	12、13	NC

7. Basic parameters of battery cell

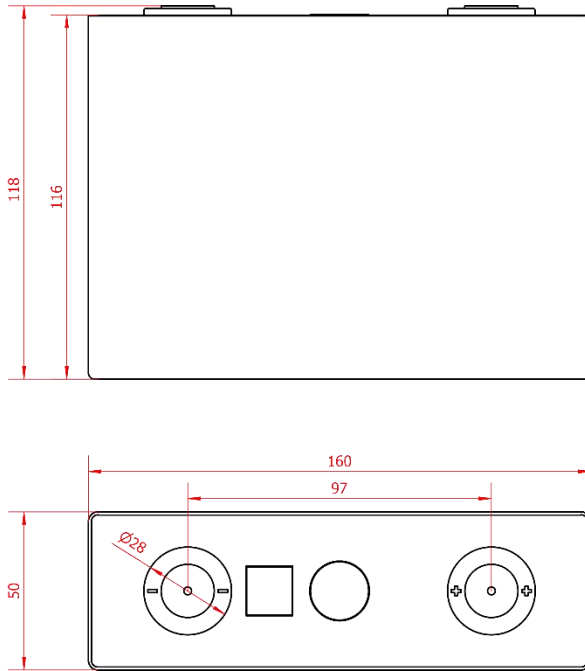

Model	LF100LA
Nominal Capacity	100Ah
Nominal Voltage	3.2V
Max charging voltage	$3.65 \pm 0.05V$
Discharge cut-off voltage	$2.5 \pm 0.05V$
Standard charging and discharging current	0.2C (20A)
Maximum continuous charging and discharging current	1C (100A)
Battery weight	$2 \pm 0.1kg$
Cycle life	≥ 4000 Cycles

8. Basic parameters of battery module

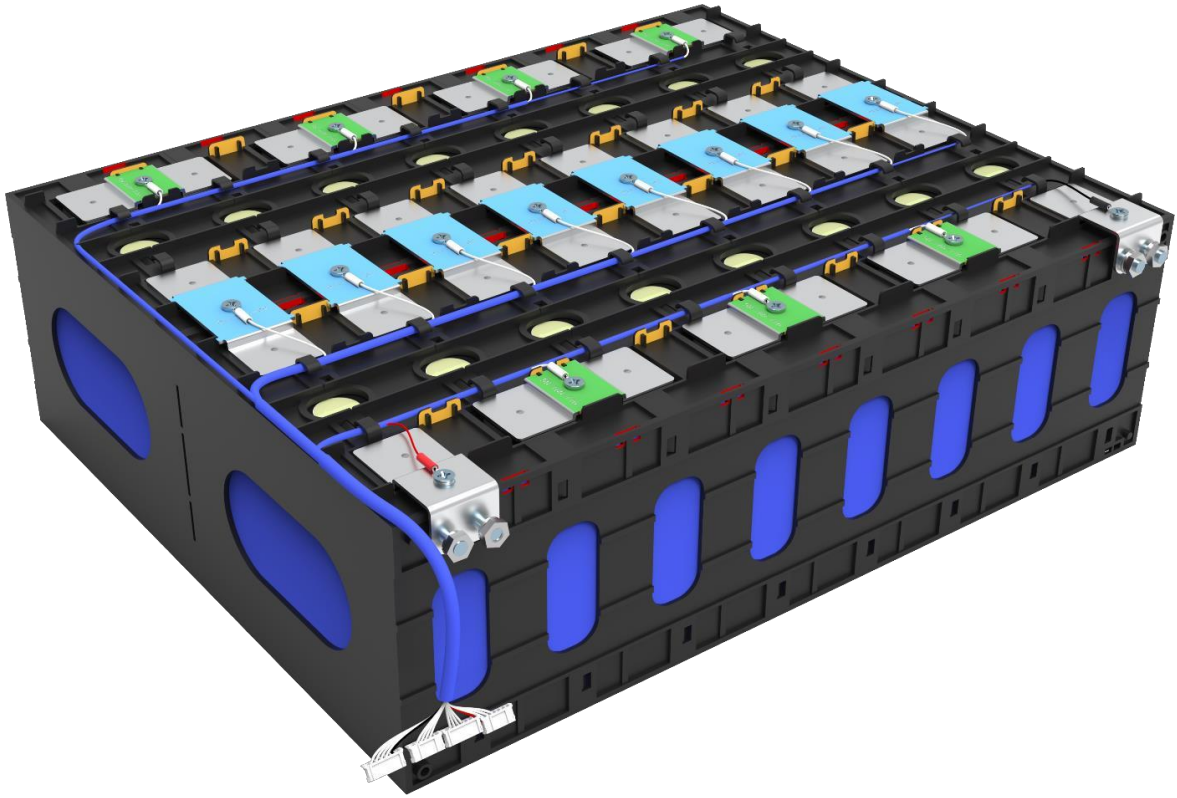

Model	LF100LA
Battery type	Lithium Iron Phosphate (LFP)
Weight	33kg±1kg
Available capacity	5120Wh
Series parallel connection method	16S1P
Connection method	Aluminum laser connection

9. Basic parameters of BMS

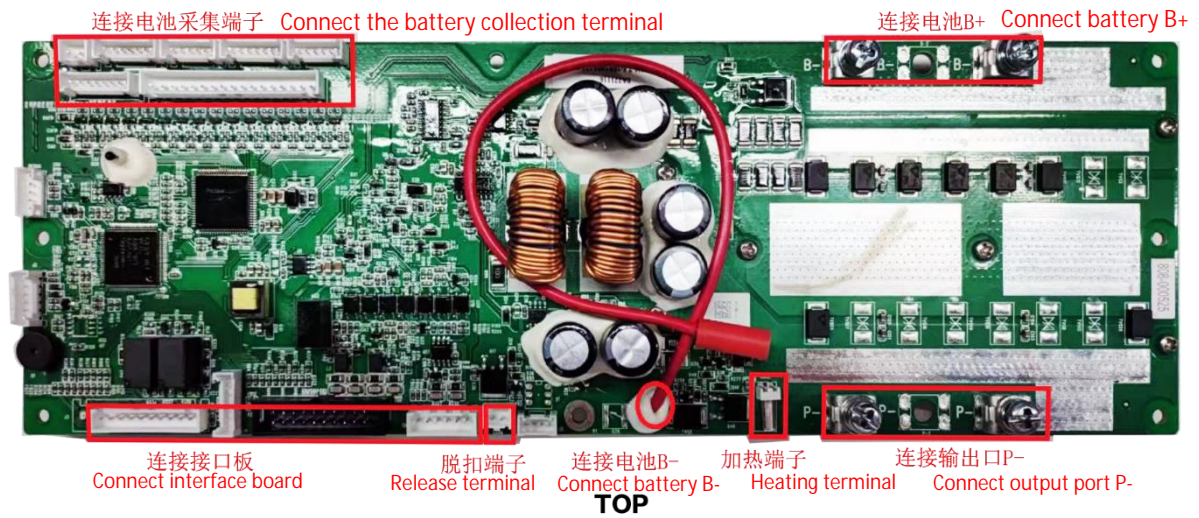

Operating Voltage	36-60V
Normal charging voltage	42-60V
Continuous charging current	100A
Continuous discharge current	100A
Overall overcharge protection	58.4V (Can be set)
Overall over discharge protection	40V (Can be set)
Overall overcharge recovery	53.6V (Can be set)
Overall over discharge recovery	47.2V (Can be set)
Product size	mainboard: 300*100*40mm
	interface board: 160*45*20mm



10. Instructions for use

10.1 Charging requirements

Charging requirements are regulations that ensure safe and effective charging. Please make sure to comply with the following charging requirements:

1. The charging current shall not exceed the maximum charging current specified in the specifications.
2. The charging voltage shall not exceed the voltage range specified in the specifications.
3. The design of the charger must meet the condition that the charging voltage does not exceed the maximum charging voltage of the battery.
4. During the charging process, the battery must be charged within the ambient temperature range specified in the specifications.
5. Reverse charging is strictly prohibited. Please ensure that the positive and negative terminals of the battery are correctly connected to avoid reverse charging.

Adhering to these charging requirements can ensure the safety of the charging process while protecting the lifespan of the device and battery.

10.2 Discharge requirements

Discharge requirements are also regulations that ensure safe and effective use of batteries. Please comply with the following discharge requirements:

1. The discharge current shall not exceed the maximum discharge current specified in the specifications. During the discharge process, the battery must be discharged within the ambient temperature range specified in the specifications.
2. To prevent excessive discharge caused by battery self consumption, it is recommended to charge every three months. If the storage time exceeds six months, it is recommended to charge and discharge the battery every six months to activate it.
3. Adhering to these discharge requirements can ensure the normal use of the battery and extend its lifespan. Please pay attention to regular charging and discharging to maintain the performance of the battery.

10.3 Storage Requirements

Storage requirements are regulations that ensure that batteries can remain in good condition when not in use. Please comply with the following storage requirements:

1. The battery pack should be stored at room temperature (15-25 °C) and humidity of 60 ± 20% RH.
2. Before storage, the battery should be charged to 40% to 60% of its capacity. If the battery is planned to be stored for more than 30 days, the state of charge (SOC) of the battery should be adjusted to approximately 50%. After three months of storage, a charge and discharge should be performed to readjust the SOC to 50%.

If the battery is stored with 50% SOC for more than 6 months without charging and discharging maintenance, it may result in approximately 5% irreparable capacity loss. If the battery is stored with 50% SOC for more than 9 months without charging and discharging maintenance, it may cause capacity loss or other defects to the battery, and we will not be responsible for warranty in this case.

Adhering to these storage requirements can protect the performance and lifespan of batteries, ensuring their normal operation when needed. Please pay attention to regular charging and discharging maintenance to maintain the condition of the battery.

10.4 Shipment electrified

The charged capacity of the shipment refers to the charging state that the battery should have during transportation. According to different transportation methods, the electrical quantity requirements for shipment are as follows:

1. The electric charge requirement for air transportation is within the range of 20% to 30% SOC (State of Charge).
2. The electrification requirement for ocean or land transportation is within the range of 40% to 60% SOC.

Adhering to these requirements can ensure the safety of batteries during transportation and reduce potential risks. Please ensure that the charged capacity of the battery is within an appropriate range according to the transportation method when arranging the transportation of the battery.



11. Warning

To ensure safe use of battery packs, the following are some usage rules and precautions:

1. It is prohibited to disassemble or change the external structure of the battery. Do not disassemble or alter the external structure of the battery on your own.
2. Use a dedicated lithium-ion battery charger for charging. Ensure to choose a charger that is suitable and meets the battery specifications for charging.
3. It is prohibited to use the battery pack by reversing the positive and negative poles. Connect the wires correctly to ensure that the positive and negative terminals of the battery are connected correctly.
4. It is prohibited to directly connect the battery pack to the power socket. Avoid directly connecting the battery pack to a power outlet.
5. It is prohibited to directly short-circuit the positive and negative poles of the battery pack with metal objects. Prevent the occurrence of short circuits.
6. It is prohibited to transport and store batteries together with metal objects. Avoid contact between batteries and metal objects to prevent potential hazards.
7. It is prohibited to strike, throw, or step on the battery pack. Prevent physical damage to the battery pack.
8. It is prohibited to hit the battery pack with sharp parts and puncture the battery pack. Avoid damaging the battery pack.
9. It is strictly prohibited to immerse the battery pack in seawater or water. Avoid contact between batteries and water to prevent dangerous situations.
10. It is prohibited to use the battery pack in high-temperature environments, such as sources of fire, heaters, strong sunlight, or in extremely hot cars. Avoid the impact of high temperature environments on the battery pack.
11. It is prohibited to directly weld battery packs or cells. Direct welding operations on battery packs are not allowed.
12. It is prohibited to use battery packs in environments with strong static electricity and strong magnetic fields. These environments may have an impact on the safety protection devices of battery packs, leading to safety hazards. When the battery experiences a short circuit, collision, or falling, it should be immediately marked and isolated. Even if the battery appears to be functioning properly, it must not be used again. Handle the problematic battery properly. Please make sure to follow the above usage rules and precautions to ensure the safe use of the battery pack and prevent potential hazards.

12. Attention

1. Please ensure that the voltage and current generated by the load do not exceed the reverse voltage and current withstand values of the BMS (battery management system) to avoid damaging the BMS board.
If the battery leaks, do not rub your eyes with your hands. Immediately rinse with water and seek medical treatment to avoid eye injuries.
3. If there are any abnormal situations during the use or storage of the battery, such as odor, heat, discoloration, deformation, or abnormal charging process, please stop using it immediately and remove the battery from the charger or device.
4. Before using the battery, make sure to clean the battery connection contacts to ensure good contact and avoid performance degradation.
5. Waste batteries should be wrapped with insulating paper around the electrodes to prevent dangerous situations such as short circuits, smoking, or fires.
6. Please follow the above precautions to ensure safe use of the battery. If encountering problems or abnormal situations, please take appropriate measures or consult professionals in a timely manner.

13. Warranty

According to company policy, the shelf life of batteries is a maximum of 4 years, calculated from the date of shipment. If our after-sales technical personnel confirm that the product malfunction is caused by their own quality problems, rather than user abuse, incorrect use, self disassembly, intentional damage, or other force majeure external factors, our company will be responsible for warranty of the product. If it is found through evaluation that the battery defect cannot be repaired, we will provide the customer with a new battery replacement.

Therefore, if the battery you purchased has quality problems within its warranty period and is confirmed by after-sales technical personnel, we will provide you with warranty services. Please provide corresponding purchase vouchers and detailed problem descriptions, and our after-sales team will assist you in evaluating and resolving the issue.



The following are the warranty details:

13.1. Power supply machine:

The warranty period is 4 years, and the host has functional problems and cannot be used normally. If the machine cannot be turned on or off, charging and discharging fail, the display screen does not light up, and the indicator light does not light up.

13.2. Cell:

The warranty period is 4 years, with severe bulging, leakage from the casing, detachment of connecting pieces, and rapid capacity degradation.

13.3. Vulnerable parts:

The warranty period is 2 years, and components such as input and output ports, switches, and buttons that are prone to wear and tear.

13.4. Accessories:

The warranty period is one year, and accessories such as positive and negative power cables, communication data cables, and installation screws are included.

13.5. Packaging:

Packaging boxes, pearl cotton, and other packaging items are not covered by the warranty.

If you have special needs for the selected product that exceed our warranty policy, we suggest negotiating with our sales representative at the time of purchase and entering into a separate special warranty service agreement applicable to that product. We will wholeheartedly provide you with solutions that meet your special needs and provide corresponding warranty services according to the agreement. Please contact our sales representative to discuss and negotiate your special warranty needs in detail.

16. Other matters

1. Please carefully read the product manual and follow the instructions in the manual before using the battery. Incorrect use may cause the battery to heat up, crack, catch fire, be damaged or lose capacity, and may even cause personal and property damage.
2. If the customer intends to use the battery beyond the scope specified in the document or under special usage conditions, please contact us in advance. We need to conduct specific experiments and tests to verify the performance and safety of the battery under these conditions.
3. Our company shall not be responsible for any losses or accidents caused by the use of this product beyond the scope specified in the document.
4. Unless mutually agreed upon, matters not mentioned in this specification shall not have legal effect.
5. Without prior notice to the customer, our company has the right to upgrade and adjust the performance or specification parameters of the product.